



Republic of Serbia

EDICT OF GOVERNMENT

In order to promote public education and public safety, equal justice for all, a better informed citizenry, the rule of law, world trade and world peace, this legal document is hereby made available on a noncommercial basis, as it is the right of all humans to know and speak the laws that govern them.

SRPS EN 13595-2 (2008) (English): Protective clothing for professional motorcycle riders - Jackets, trousers and one-piece or divided suits - Part 2: Test method for determination of impact abrasion resistance [Authority: The European Union Per Directive 89/686/EEC]



BLANK PAGE



SRPSKI
STANDARD

SRPS EN 13595-2

Septembar 2008.

Identičan sa EN 13595-2:2002

**Zaštitna odeća za profesionalne vozače
motocikala — Jakne, pantalone, jednodelna ili
višedelna odela —
Deo 2: Metoda ispitivanja za određivanje
otpornosti prema habanju pri udaru**

*Protective clothing for professional motorcycle riders — Jackets,
trousers and one-piece or divided suits —
Part 2: Test method for determination of impact abrasion resistance*

I izdanje



AUTORSKA PRAVA ZAŠTIĆENA

Autorska prava za srpske standarde i srodne dokumente pripadaju Institutu za standardizaciju Srbije. Umnožavanje, u celini ili delimično, kao i distribucija srpskih standarda i srodnih dokumenata, dozvoljeni su samo uz saglasnost Instituta za standardizaciju Srbije.

© ISS

Izdaje Institut za standardizaciju Srbije

INSTITUT ZA STANDARDIZACIJU SRBIJE
11030 Beograd, Stevana Brakusa 2, p.f. 2105

Telefoni: (011) 35-41-260, 35-41-261
Telefaks: (011) 35-41-257
Prodaja: (011) 25-47-496
Informacioni centar: (011) 25-47-293

jusI@jus.org.yu
prodaja@jus.org.yu

www.jus.org.yu

INVOICE No. 1825

Ovaj standard doneo je direktor Instituta za standardizaciju Srbije rešenjem br. 1218/34-52-01/2008 od 9. septembra 2008. godine.

Ovaj standard je identičan sa evropskim standardom EN 13595-2:2002 i objavljen je uz dozvolu Evropskog komiteta za standardizaciju CEN, rue de Stassart 36, B-1050 Brussels.

CEN i njegove članice u potpunosti zadržavaju sva prava reprodukcija i umnožavanja evropskih standarda u bilo kom obliku i na bilo koji način i oni se ne mogu umnožavati bez pisanog odobrenja CEN-a Institutu za standardizaciju Srbije.

This standard is identical with EN 13595-2:2002 and is reproduced by permission of CEN, rue de Stassart 36, B-1050 Brussels.

All exploitation rights of the European Standards in any form and by any means are reserved world-wide to CEN and its National Members, and no reproduction may be undertaken without the expressed permission in writing by CEN through the Institute for Standardization of Serbia.

Nacionalni predgovor

Ovaj standard pripremila je Komisija za standarde iz oblasti zaštitne odeće i zaštitne opreme, KS F094.

Standard SRPS EN 13595-2 nastao je preštampavanjem engleske verzije evropskog standarda EN 13595-2:2002.

Veza srpskih dokumenata i citiranih evropskih dokumenata

SRPS EN 13595-1:2008, *Zaštitna odeća za profesionalne vozače motocikala — Jakne, pantalone i jednodelna ili višedelna odela — Deo 1: Opšti zahtevi* (EN 13595-1:2002, IDT)

EN 388:1994 na koji se ovaj standard normativno poziva primenjuje se za potrebe ovog standarda pošto nije preuzet kao identičan srpski dokument.

EUROPEAN STANDARD

EN 13595-2

NORME EUROPÉENNE

EUROPÄISCHE NORM

September 2002

ICS 13.340.10

English version

Protective clothing for professional motorcycle riders - Jackets,
trousers and one-piece or divided suits - Part 2: Test method for
determination of impact abrasion resistance

Vêtements de protection pour les motocyclistes
professionnels - Vestes, pantalons et combinaisons une ou
deux pièces - Partie 2: Méthode d'essai pour déterminer la
résistance à l'abrasion par impact

Schutzkleidung für professionelle Motorradfahrer - Jacken,
Hosen und ein- und mehrteilige Anzüge - Teil 2:
Prüfverfahren zur Bestimmung der Stoßabriebfestigkeit

This European Standard was approved by CEN on 1 August 2002.

CEN members are bound to comply with the CEN/CENELEC Internal Regulations which stipulate the conditions for giving this European Standard the status of a national standard without any alteration. Up-to-date lists and bibliographical references concerning such national standards may be obtained on application to the Management Centre or to any CEN member.

This European Standard exists in three official versions (English, French, German). A version in any other language made by translation under the responsibility of a CEN member into its own language and notified to the Management Centre has the same status as the official versions.

CEN members are the national standards bodies of Austria, Belgium, Czech Republic, Denmark, Finland, France, Germany, Greece, Iceland, Ireland, Italy, Luxembourg, Malta, Netherlands, Norway, Portugal, Spain, Sweden, Switzerland and United Kingdom.



EUROPEAN COMMITTEE FOR STANDARDIZATION
COMITÉ EUROPÉEN DE NORMALISATION
EUROPÄISCHES KOMITEE FÜR NORMUNG

Management Centre: rue de Stassart, 36 B-1050 Brussels

© 2002 CEN All rights of exploitation in any form and by any means reserved
worldwide for CEN national Members.

Ref. No. EN 13595-2:2002 E

INVOICE No. 1825

Contents

	page
Foreword.....	3
Introduction	4
1 Scope	4
2 Normative references	4
3 Terms and definitions.....	4
4 Determination of impact abrasion resistance.....	5
4.1 Principle.....	5
4.2 Apparatus	5
4.3 Test specimens	7
4.4 Procedure	7
4.5 Test report	8
Annex ZA (informative) Clauses of this European Standard addressing essential requirements or other provisions of EU Directives	12

Foreword

This document EN 13595-2:2002 has been prepared by Technical Committee CEN/TC 162 "Protective clothing including hand and arm protection and lifejackets", the secretariat of which is held by DIN.

This European Standard shall be given the status of a national standard, either by publication of an identical text or by endorsement, at the latest by March 2003, and conflicting national standards shall be withdrawn at the latest by March 2003.

This document has been prepared under a mandate given to CEN by the European Commission and the European Free Trade Association, and supports essential requirements of EU Directive(s).

For relationship with EU Directive(s), see informative annex ZA, which is an integral part of this document.

This standard is part of a series of standards specifying requirements for particular items of clothing or particular performance levels and hazards. EN 13595 comprises four parts:

Part 1: General requirements;

Part 2: Test method for determination of impact abrasion resistance;

Part 3: Test method for determination of burst strength;

Part 4: Test method for determination of impact cut resistance.

According to the CEN/CENELEC Internal Regulations, the national standards organizations of the following countries are bound to implement this European Standard: Austria, Belgium, Czech Republic, Denmark, Finland, France, Germany, Greece, Iceland, Ireland, Italy, Luxembourg, Malta, Netherlands, Norway, Portugal, Spain, Sweden, Switzerland and the United Kingdom.

Introduction

The only protection a motorcyclist involved in a road traffic accident has against injury is the clothing he or she is wearing at the time. Motorcyclists' clothing is generally worn as an extension of normal clothing, providing protection against ambient conditions of wind, water and cold, but it should also provide some protection from injury in the event of an accident. It is intended not to hinder a rider from controlling his machine. It should be of an acceptable appearance to the wearer.

This European Standard is primarily concerned with the protection provided by clothing against injury in accidents. The hazards to which motorcyclists are exposed vary widely depending on the physical environment such as the nature of the road track or mountainside, the climatic environment, the traffic environment, the speed at which the motorcycle is being ridden and the skill of the rider. The number of combinations of possible hazards is very large. Total clothing performance against every identified hazard could be required for each combination. This would be impracticably complicated. Therefore this standard contains the requirements for single characteristics of single items of clothing or simple combinations of garments.

This standard is part of a series of standards specifying requirements for particular items of clothing or particular hazards. Further Parts will be issued in due course.

1 Scope

This European Standard specifies a test method for assessment of protection efficiency of professional motorcycle riders jackets, trousers and one-piece and divided suits which are intended to protect the wearer against mechanical injury on metallated road surfaces.

2 Normative references

This European Standard incorporates by dated or undated reference, provisions from other publications. These normative references are cited at the appropriate places in the text, and the publications are listed hereafter. For dated references, subsequent amendments to or revisions of any of these publications apply to this European Standard only when incorporated in it by amendment or revision. For undated references the latest edition of the publication referred to applies (including amendments).

EN 388:1994, *Protective gloves against mechanical risks*.

EN 13595-1:2002, *Protective clothing for professional motorcycle riders — Jackets, trousers and one-piece or divided suits — Part 1: General Requirements*.

3 Terms and definitions

For the purposes of this European Standard, the following terms and definitions apply.

3.1

chamois leather

leather made from the flesh split of sheepskin or lambskin, or from sheepskin or lambskin from which the grain has been removed by frizing, and tanned by processes involving oxidation of marine oils in the skin, using either solely such oils (full-oil chamois) or first an aldehyde and then such oils (combination chamois)

3.2**professional rider**

a person who is employed to provide or contracts to perform for reward, the services requiring the riding of a motorcycle

Examples are:

- a) the delivery of letters, packets or other small freight;
- b) the transport of passengers by motorcycle;
- c) emergency medical treatment;
- d) vehicle breakdown support.

4 Determination of impact abrasion resistance**4.1 Principle**

A test specimen is dropped from a set height onto an abrasive belt moving at a fixed speed over a rigid horizontal surface. The time for the specimen to fully abrade is measured by detecting the difference in time between the breaking of two electrical wires, one passing over the outer and one over the inner surface of the specimen.

4.2 Apparatus**4.2.1** Apparatus conforming to the following characteristics:

— Belt speed	8 m/s
— Belt grit	OP 60
— Abraded area	1963 mm ²
— Static force on sample	49 N
— Static pressure on sample	25 kPa
— Drop height	50 mm

A suitable apparatus consists of the following units illustrated in Figures 1, 2 and 3. Numbers in parentheses refer to those on the figures.

- a) A 750 W motor or larger driving a high mass roller (2) (10 kg or more) with a diameter of more than 150 mm.
- b) A high mass roller (3) (10 kg or more) that is not driven.
- c) An OP 60 aluminium oxide abrasive grit belt (4) passing around the two rollers and tensioned. The rollers are cambered - i. e. having a larger diameter at their mid points - to keep the belt centred.
- d) A horizontal robust steel plate (5) more than 20 mm thick over which the top run of the belt passes.
- e) A belt cleaning and dust removing system. The following is used:
 - 1) A cylindrical brush (6) 200 mm in diameter, driven by a second motor. The polypropylene bristles of the brush are 0,2 mm in diameter with a free length of 45 mm; there are approximately 200 000 bristles in a brush 200 mm long which fits the belts used. The brush is run so that the bristles just touch the belt as it goes over the roller. The bristles have a tip speed three times that of the belt and in the same direction.

- 2) Two dust extraction points, one (7) before and one (8) after the brush. These consist of tubes directed across the belt and ground down so that a slit is formed facing the belt. The tubes are positioned very close to but not touching the belt as it goes over the roller. The first removes coarse material and the second fine dust left by the brush. (The first tube can be replaced by a high flow widebore extraction).
- f) A rigid pendulum (9) with the sample holder (12) mounted at its end. The pendulum is horizontal during abrasion and may be raised to a desired height and released by a suitable mechanism (10). The pendulum has a pivot (11) that permits movement only in a vertical plane. The pendulum position can be adjusted laterally so that 3 tracks can be used on each belt. The pendulum is of light construction with adjustable masses attached above the sample (13) to give a force of 49 N measured below the sample.
- g) The sample holder is constructed of metal with the dimensions in Figure 2. It consists of a top plate (14), sample holder (15) and face plate 75 mm in diameter (16) which for convenience are connected by a screw thread cut on the outside of the body.
- h) The face plate has a central flat face 40 mm in diameter (17), which is surrounded by a curved area 15 mm wide with a radius of curvature of 35 mm (18). The remainder of the face area is smoothly contoured into the vertical side of the face plate (19).
- i) The face plate is covered with one layer of sheepskin chamois leather 0,8 mm to 1,0 mm thick (20) attached with elastic adhesive. After ten or more impacts on a flat surface as in the test, but without a belt in place the flattened area is 45 mm to 47 mm in diameter and remains constant thereafter.
- j) The face plate with chamois is covered by two 160 mm disks of cotton denim fabric (21), which are stretched over the face plate and secured by thick rubber elastic bands around the body of the sample holder.
- k) The sample (12) is stretched evenly over the denim and held in place by a metal hose clip (22). Samples are normally disks 160 mm in diameter. Thick composite samples with foam layers need to be wider.
- l) Two insulated copper wires ca. 0,14 mm in diameter are held in place with adhesive tape on the side of the specimen holder. One is between the sample and the denim (23) and the other (24) is on the face of the sample. The wires are placed so as to lie flat and at approximately 45 degrees to the direction of travel of the belt.
- m) The two wires are connected (25) to a suitable measuring apparatus so that the time between the breaking of the first wire and the breaking of the second can be measured to an accuracy of 10 ms.
- n) A manual mechanism (26) for lifting the sample holder off the belt directly the second wire is broken.
- o) A complete enclosure (27) for the apparatus with dust extractor (28) to protect the operators from flying fragments, moving parts and dust.
- p) Common earthing of metal parts in the apparatus, and metal dust extraction tubing, and earthed metal shielding of the dust collection systems if they are within close proximity. These measures reduce problems that could be encountered in false triggering of the recording apparatus by electrostatic discharges in the apparatus and particularly in the dust extraction systems.

4.2.2 Abrasive belts of the following specification: polyester fabric backing; aluminium oxide grit of size OP 60; the grit is resin bonded, closely spaced and not "super-sized" (that is without glue or resin over the grit filling the voids between the grit particles); the grit is electrostatically deposited onto the belt, not spread by gravity feed.

NOTE This type of belting is available from many manufacturers. Product P60 Y AO Poly BX 139 from English Abrasives and Chemicals PLC, Marsh Lane, London N17 OXA, UK., has been found satisfactory.

4.2.3 Reference material cotton canvas as specified in EN 388 with the following characteristics:

- fabric warp and weft: cotton spun from open end fibres;
- linear mass warp and weft: 161 Tex;

- twist warp: double twist S 280 t/m; single yarn Z 500 t/m;
- twist weft: same as warp;
- warp: 18 threads per 10 mm;
- weft: 11 threads per 10 mm;
- crimp warp: 29 %;
- crimp weft: 4 %;
- tensile strength in warp: 1 400 N;
- tensile strength in weft: 1 000 N;
- mass per unit area: 540 g/m²;
- thickness: 1,2 mm.

NOTE Such a canvas is made by Collantis, P. O. Box 3, 59930 La Chapelle d'Armantières, France, and is available after verification under reference LEM 6 from L'Institut Français Textile-Habillement, Avenue Guy de Collongue, 69134 Ecully, CEDEX, France.

A secondary reference fabric, as described in EN 388:1994, 6.2.4, of "15 oz" waxed cotton canvas can be used in routine testing. Its performance is calibrated against the reference canvas.

4.3 Test specimens

For all zones test specimens at least 500 mm x 500 mm of each layer of material present in the garment that has an abrasion resistance requirement shall be taken. For testing of sheet materials, three test specimens of at least 500 mm x 500 mm shall be provided, and the test procedure shall accurately replicate the use of the material(s) in finished garments.

Samples shall represent every combination of materials in the panels of the garment in zones 2, 3 and 4 (see EN 13595-1:2002, annex C). All layers of material present at the sampling point, excluding removable impact protectors, shall be taken. Specimens shall be not less than 160 mm diameter cut through all layers of the garment or from identical materials supplied with the garment. Not less than six specimens shall be prepared for test from each combination of materials identified in the garment. Multiple layers are stapled together at one point at the edge of the specimen to maintain their relative orientations. Specimens are marked with the orientation of abrasion to be carried out.

Stretch panels are cut into 160 mm diameter discs. Each specimen is stretched in its most compliant direction with a force of 30 N, and adhesive paper tape is stuck across the outside face of the stretch panel. When the specimen is mounted on the holder the degree of stretch is arranged so that the paper tape is taut. Before abrasion testing the tape is removed. Reference specimens consisting of two layers of cotton canvas 160 mm in diameter should be prepared. The warp direction should be marked. The two layers should have their warp fibres running in the same orientation.

4.4 Procedure

4.4.1 Test sequence

Mount the cotton canvas reference specimens on the sample holder over two layers of the cotton denim. The warp fibres shall run in the direction of belt movement. One trigger wire is below the canvas and one above. The pendulum is supported by the released mechanism so that the face of the canvas is 50 mm ± 5 mm above the abrasive grit belt when this is in contact with the supporting table.

Dimensions in millimetres

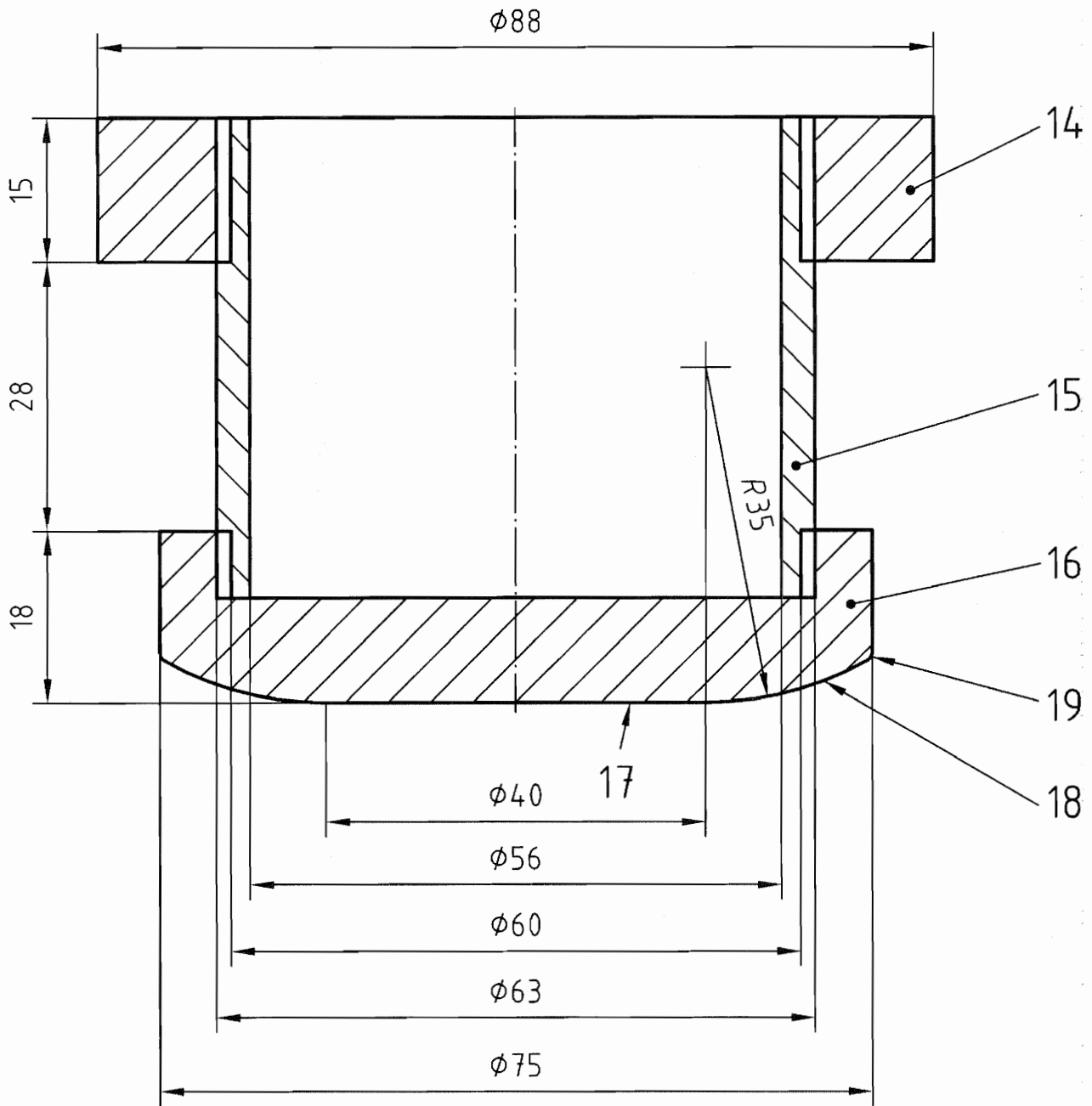

Key

- 14 Top plate
- 15 Specimen holder
- 16 Face plate
- 17 Flat face of 16
- 18 Curved area
- 19 Vertical side of 16

Figure 2 — Dimensions of sample holder

PUBLIC RESOUKLE, 954/2 SEBASJOPOL, CA. 1005 GRAVENS TEIN HIGWAY NOKTHHJ. OKTOBR 2012/11. OKTOBR 2012

Dimensions in millimetres

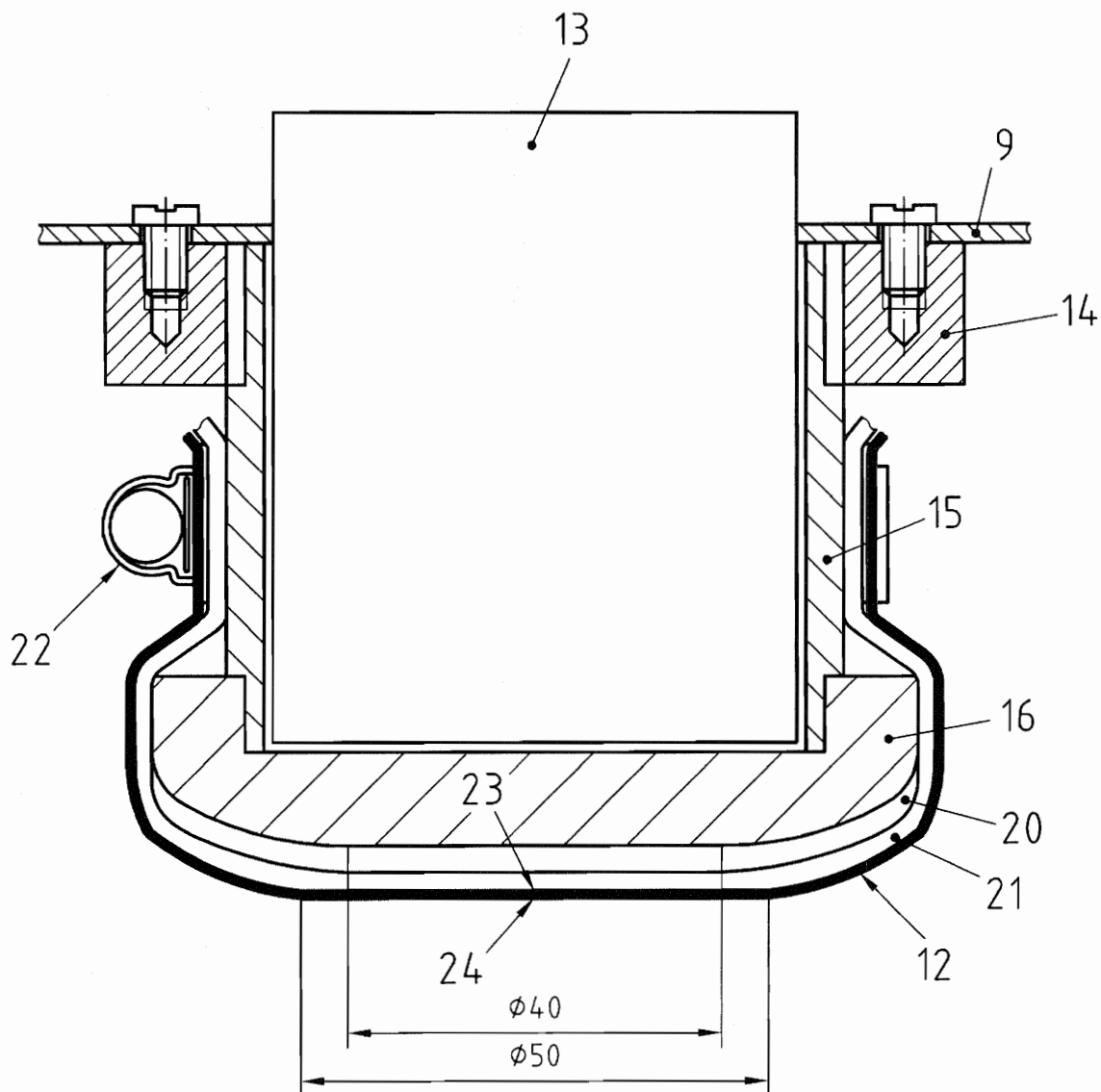

Key

- 9 Rigid pendulum
- 12 Specimen
- 13 Falling mass
- 14 Top plate
- 15 Specimen holder
- 16 Face plate
- 20 Thin leather
- 21 Two cotton disks
- 22 Clip
- 23 Inner copper wire
- 24 Outer copper wire

Figure 3 — Detail of the clamping system for samples on the sample holder

Annex ZA (informative)

Clauses of this European Standard addressing essential requirements or other provisions of EU Directives

This European Standard has been prepared under a mandate given to CEN by the European Commission and the European Free Trade Association and supports essential requirements of EU Directive 89/686/EEC.

WARNING : Other requirements and other EU Directives may be applicable to the product(s) falling within the scope of this European Standard.

The clauses of this European Standard are likely to support requirements of Directive 89/686/EEC, Annex II, clause 3.3.

Compliance with the clauses of this European Standard provides one means of conforming with the specific essential requirements of the Directive concerned and associated EFTA regulations.

ICS 13.340.10

Klasifikaciona grupa Z.B1

Deskriptori: zaštitna odeća, vozači motocikala, ergonomska svojstva, udarac, otpornost prema habanju

Descriptors: protective clothing, motorcycle riders, ergonomic characteristics, impact, abrasion resistance

Ukupno strana 14

